

LEAKAGE MEASUREMENT WITH AN Remote PHY Device(RPD)

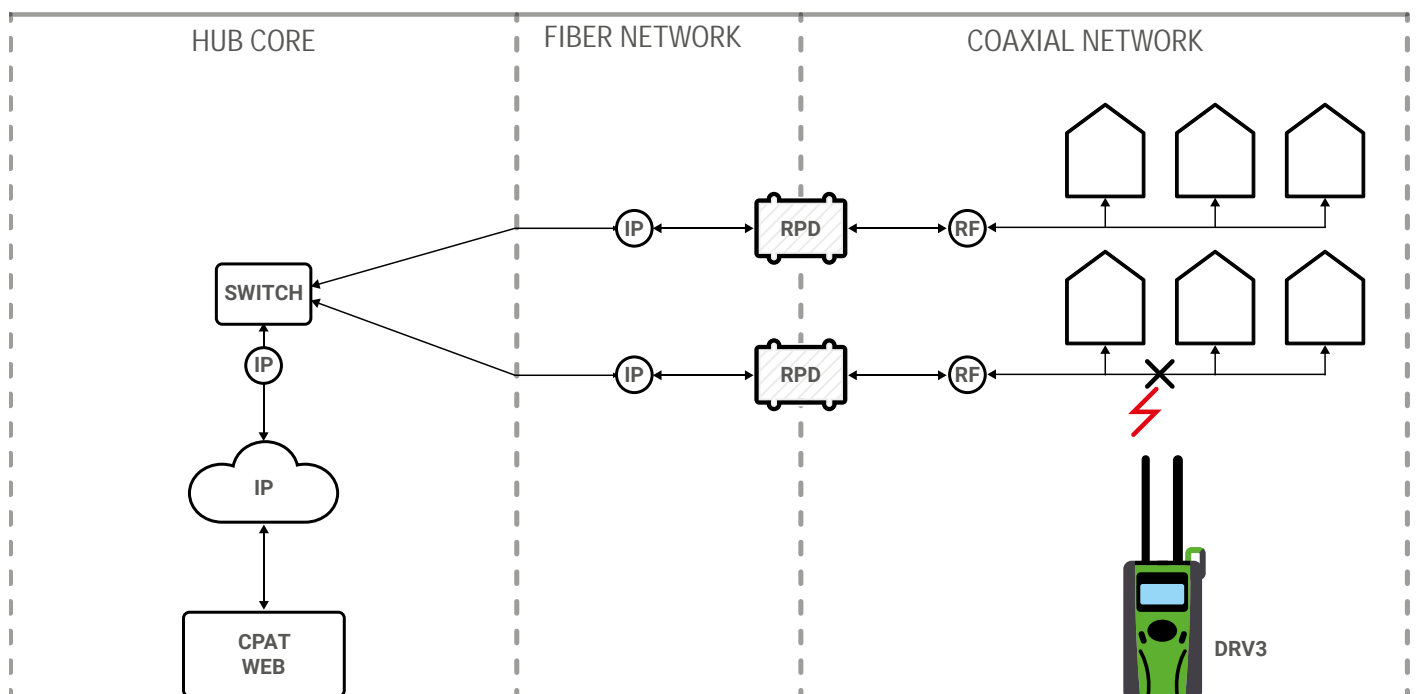

Did you know you can use the DRV3 to measure leakage in R-PHY and RMAC-PHY infrastructures? The RPD will generate the test tones, and as such the DSG1 is no longer required in the headend.

For optimal results, use our proprietary dual-tone modulation using DSB-SC (Double-sideband suppressed-carrier). All RPD vendors support this type of configuration. All you need to do is configure the RPD to generate two separate tones, emulating a DSB-SC signal.

RPD configuration

For every frequency to be tested, you will need to configure two pilot tones on the RDP.

Configure each tone at + or – 3480 Hz from the center frequency.

Example: To measure leakage at 126 MHz (126 000 000 Hz).

- First pilot tone is set to $126\,000\,000 - 3480 = 125\,996\,520$ Hz.
- Second pilot tone is set to $126\,000\,000 + 3480 = 126\,003\,480$ Hz.
- The objective is to set the tones' signal level as high as possible, all the while not impairing the adjacent QAM channels. In typical setups, the average QAM channel power is about 3 dB below the peak QAM channel power, and the generated tones run about 18 dB below the average channel power.

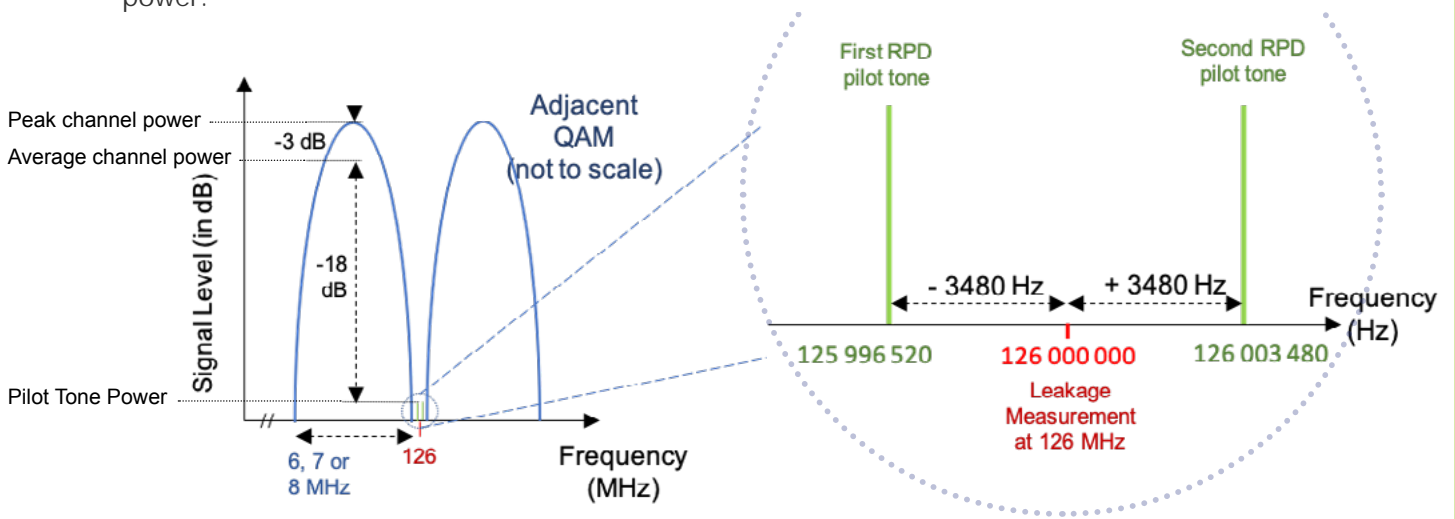

DRV3 configuration

- Set the Test Frequency as usual (e.g., 126 MHz in the Aero band).
- Set “Channel Tag Detection” to DSB-SC (or DS), mode 6348.
- Set “CW to QAM Delta” (in dB) to the signal level difference between the pilot tones and the adjacent QAM's average channel power (e.g. -18 dB).

If you would like to explore this topic and the value it can bring to your network maintenance activities, please call us or write to us. Our specialists will be pleased to answer all your questions.



TECHNICAL SUPPORT TEAM
T + 1-888-307-2728 support@cpatflex.com